

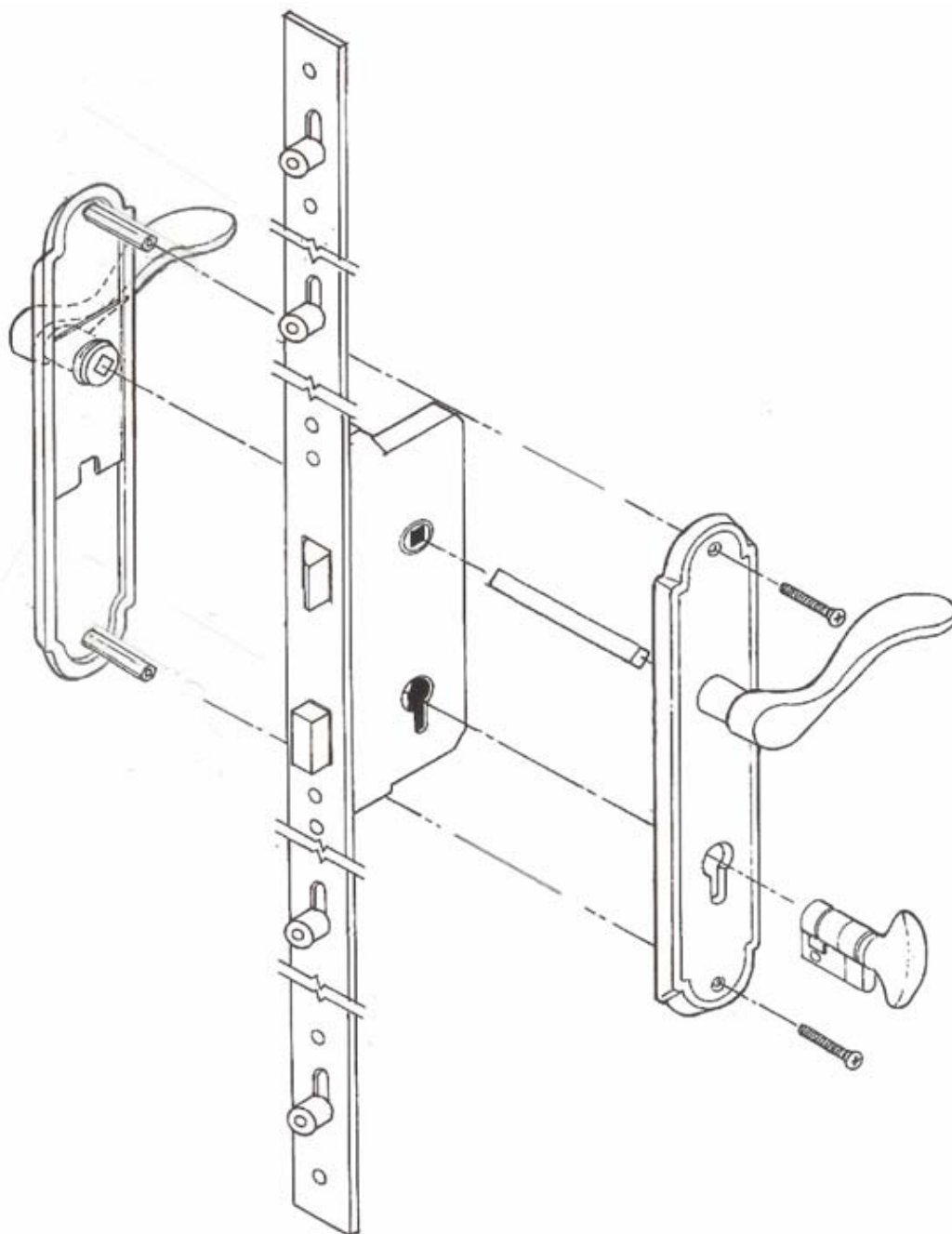

LONGLEAF
COLLECTION

INSTALLATION INSTRUCTIONS

Seamless Transaction with Enhanced Product Features delivered on time and quality correct.



Corporate Address: 9546 Hwy 211 East - Aberdeen, NC 28315
Mailing Address: PO Box 367 - Aberdeen, NC 28315
Telephone: 866-635-7155
Website: www.longleafcollection.com
Made in the USA

INSTALLATION INSTRUCTIONS



Seamless Transaction with Enhanced Product Features delivered on time and quality correct.

03.5 PROFILE FUNCTION

- A. Insert the spindle through the hub in the lock mechanism until the spindle is centered in the hub. Holding the spindle from the outside, slip on the inside trim.

- B. Mark the throughbolt locations (top and bottom screw holes) with a pencil. You may/ or may not need to drill new holes or increase the diameter of existing holes as every manufacturer has a different place for through drilling. Drill new holes if necessary.

- C. Slip the outside trim on then the inside trim and run the machine screws through. Tighten firmly. Install profile cylinder and tighten screw at the edge of door to lock down profile cylinder.