

INSTALLATION INSTRUCTIONS

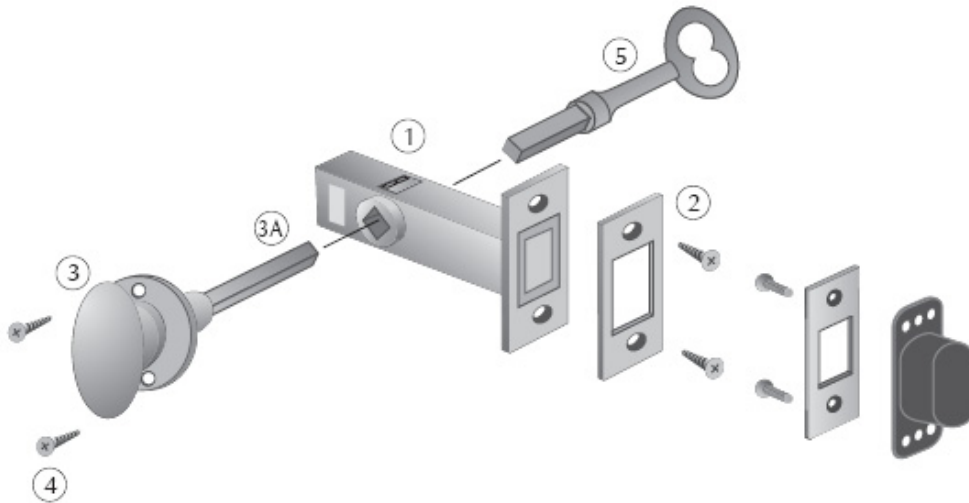

Seamless Transaction with Enhanced Product Features delivered on time and quality correct.



0219

- A. Install latch mechanism (1) into cross-bore. Be sure to orient the latch so that when the turn piece (3) is installed the latch will extend when the turn piece is rotated towards the edge of the door.
- B. Fasten latch to door with screws (2). Use a 1/8" drill bit to drill pilot holes.
- C. With the latch mechanism retracted install the turn piece, keeping the tailpiece oriented on the diamond. The tailpiece needs to be cut-to-length to fit the door thickness. It should fit 1/2 way into the hub of the latch (1), allowing for the key (5) to operate the latch from the outside of door.
- D. Position the mounting washer with the holes at 6 and 12 o'clock location. Pre-drill for screws (4) using a 1/16" drill bit.
- E. Install strike on jamb. Pre-drill for screws using a 1/8" drill bit.

Corporate Address: 9546 Hwy 211 East - Aberdeen, NC 28315
Mailing Address: PO Box 367 - Aberdeen, NC 28315
Telephone: 866-635-7155
Website: www.longleafcollection.com
Made in the USA